



# AMERICAN FLOOR PRODUCTS COMPANY, INC.

**AFco-USA**

P.O. BOX 7055 • Gaithersburg, Maryland 20898 -7055 • 301-987-0490 • Fax 301-987-0422  
 email: sales@afco-usa.com • Web Site: www.afco-usa.com

CUSTOMER P.O. #

## ZEPHER® Aluminum Grating (UX-295)

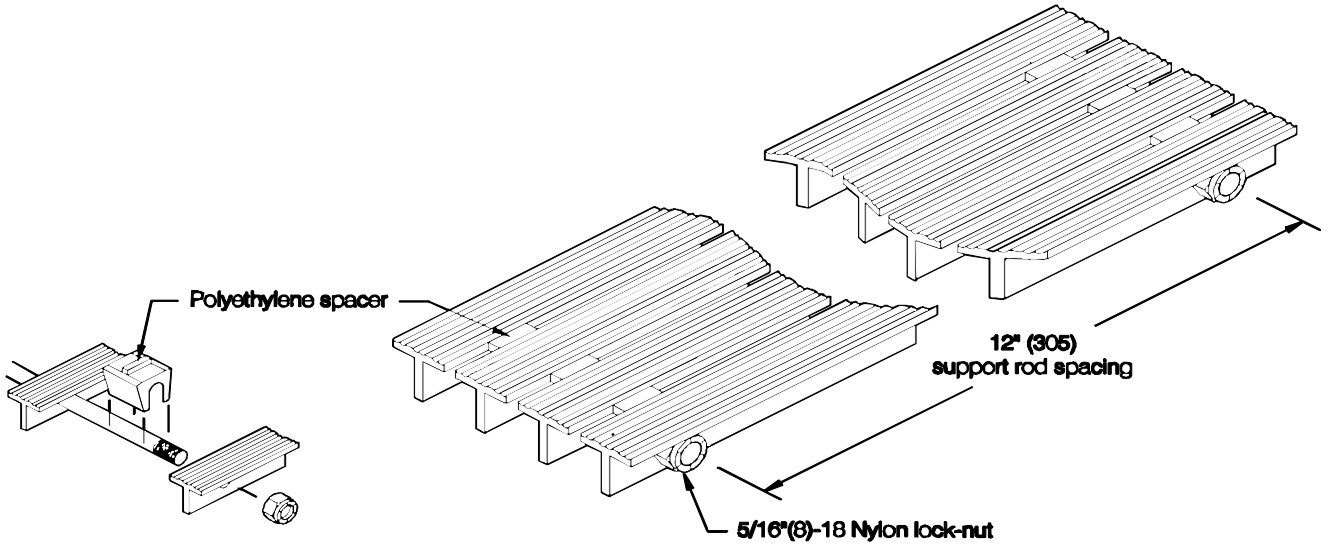
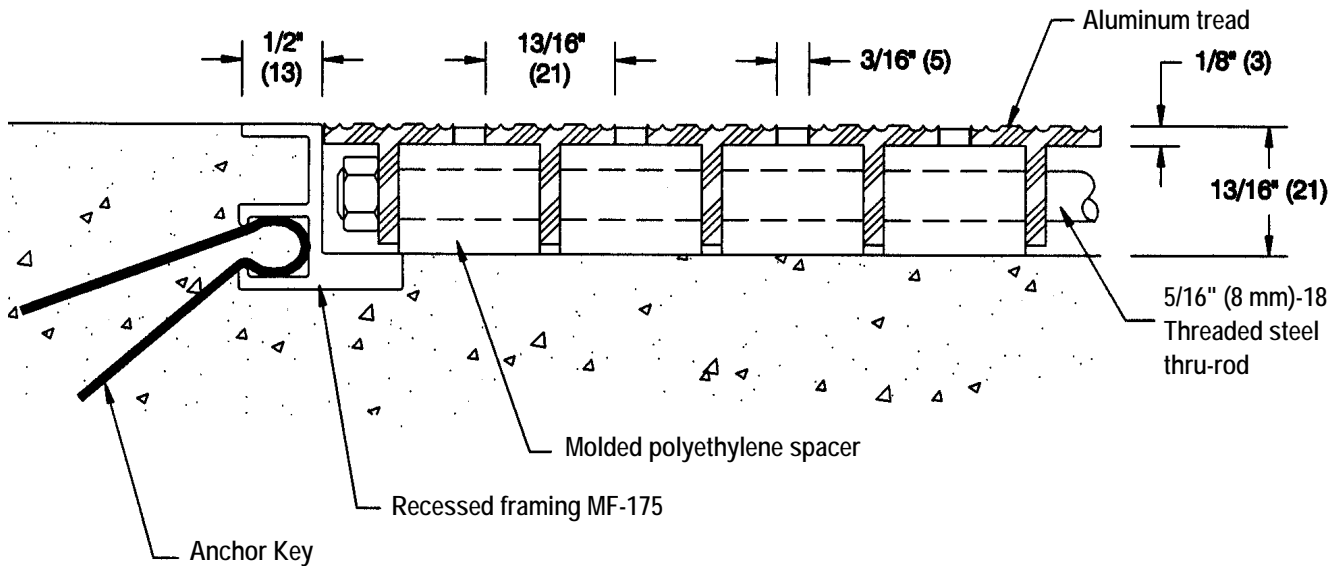

### Sectioning Information:

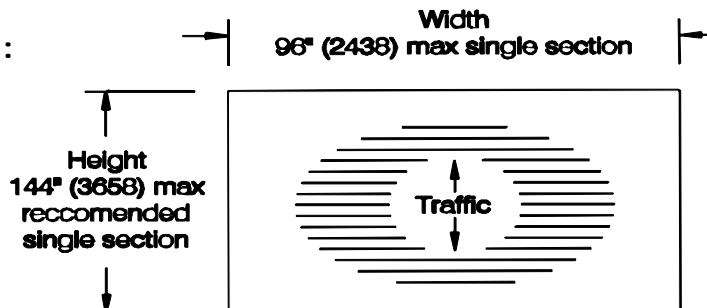

\* Mats over 96 square feet may require sectioning as determined by the factory

# ZEPHER<sup>®</sup> Aluminum Grating (UX-295)

**Features:**

- Extruded aluminum treads, 1/8" (3 mm), alloy 6063-T5
- Molded polyethylene spacer to reduce clatter and eliminate metal contact with floor
- Single section width to 96" (2438 mm)
- Static coefficient of friction (ASTM D-2047-82)  
     Dry: 0.45              Wet: 0.74

**Finishes:**

- Aluminum tread:  
     Mill finish (standard)
- Spacer:  
     Molded polyethylene white

**NOTE ON DIMENSIONS:**

American Floor Products Company, Inc. requires that exact mat opening dimensions be provided. Mats will be fabricated 1/4" (6 mm) smaller in the left to right dimensions to allow for proper fit.

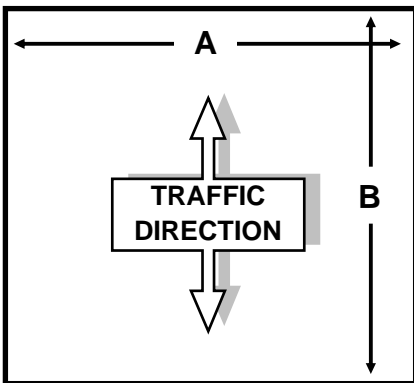

QUANTITY	DIMENSIONS A x B	SPECIAL CONSTRUCTION

JOB NAME:	ITEMS	PLEASE SPECIFY
JOB NUMBER:	Type of Frame & Finish:	
CONTRACTOR:		
ARCHITECT:		
DEALER NAME:		
APPROVED BY:	Date:	